

THIS DRAWING IS UNPUBLISHED. RELEASED FOR PUBLICATION
 © COPYRIGHT - By - ALL RIGHTS RESERVED.

LOC	DIST	REVISIONS			
P	LTR	DESCRIPTION	DATE	OWN	APVD
CM	53	AG3	REVISED PER ECR 12-013810	24SEPT12	JR TM

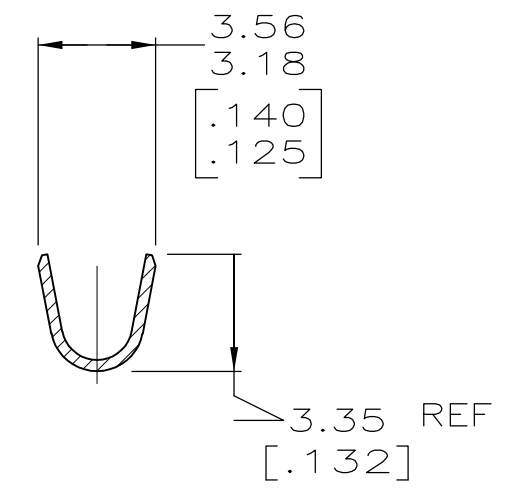
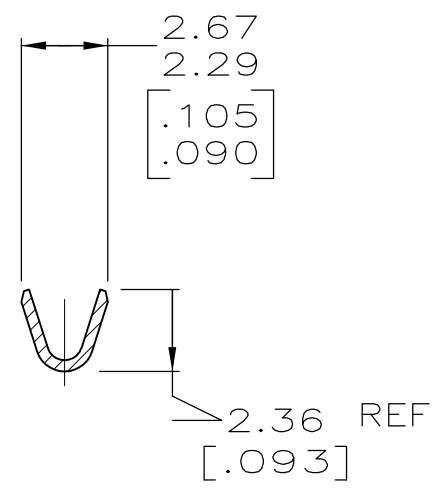
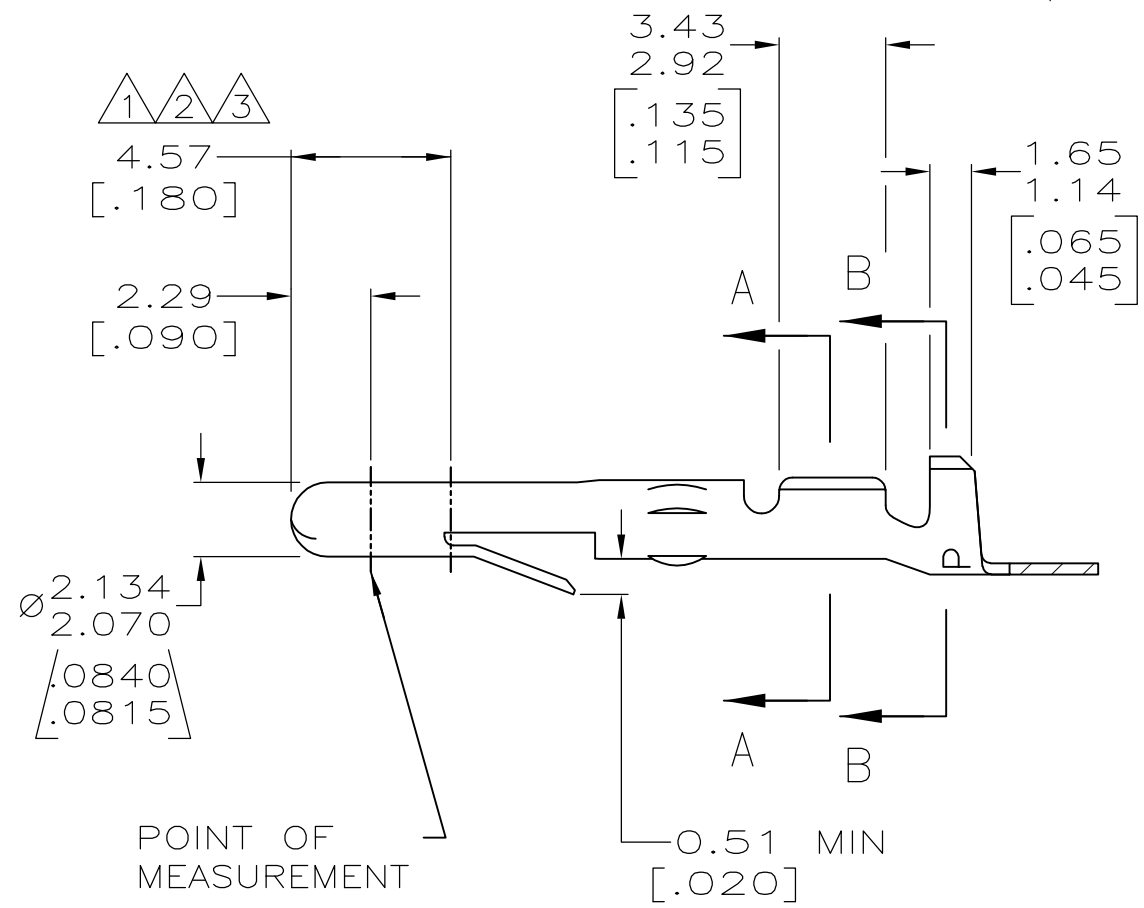
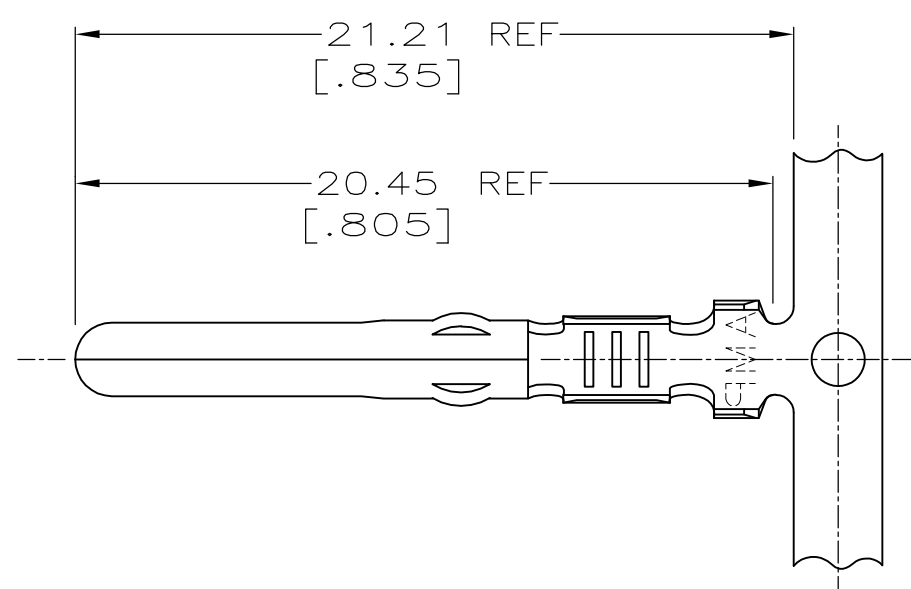

- ① PLATE OVERALL WITH 0.00127 [.000050] MIN NICKEL, THEN TIP PLATE WITH 0.00076 [.000030] MIN GOLD IN THE MATING AREA.
- ② PLATE OVERALL WITH 0.00127 [.000050] MIN NICKEL, THEN PLATE IN THE MATING AREA AND STRIPE THE INSIDE OF THE WIRE BARREL WITH 0.00076 [.000030] MIN GOLD.
- ③ PLATE OVERALL WITH 0.00127 [.000050] MIN NICKEL, THEN FLASH ENTIRE TERMINAL WITH GOLD, THEN TIP PLATE WITH 0.00076 [.000030] MIN GOLD IN THE MATING AREA.
- 4. WIRE RANGE: 0.2 - 0.9 mm² [24 - 18 AWG] .
- 5. INSULATION RANGE: 2.54 [.100] MAX DIA.
- 6. APPLICATOR TYPE: MINI.
- 7. DIMENSIONS IN BRACKETS ARE IN INCHES.

FINISH	MATERIAL	PART NO
①	0.30 [.012] BRASS	61116-7
①	0.30 [.012] PH BRZ	61116-6
②	0.30 [.012] BRASS	61116-5
PRE-TIN	0.30 [.012] PH BRZ	61116-4
-	0.30 [.012] PH BRZ	61116-3
-	0.30 [.012] BRASS	61116-2
PRE-TIN	0.30 [.012] BRASS	61116-1

METRIC

THIS DRAWING IS A CONTROLLED DOCUMENT.

DWN	T.BECK	2-18-93	TE Connectivity NAME PIN, MATE-N-LOK™
CHK	R. SWING	2-18-93	
APVD	C. MARTIN	2-24-93	
PRODUCT SPEC			
DIMENSIONS: MM [INCHES] TOLERANCES UNLESS OTHERWISE SPECIFIED: 0 PLC ± - 1 PLC ± - 2 PLC ± 0.25 [.010] 3 PLC ± - 4 PLC ± - ANGLES ± ± - FINISH SEE TABLE			APPLICATION SPEC WEIGHT SIZE CAGE CODE DRAWING NO A2 00779 C-61116
MATERIAL SEE TABLE			RESTRICTED TO
CUSTOMER DRAWING			SCALE 5:1 SHEET 1 of 1 REV AG3